

ODU/OA-1400 "JUMBO" with Polar mount for

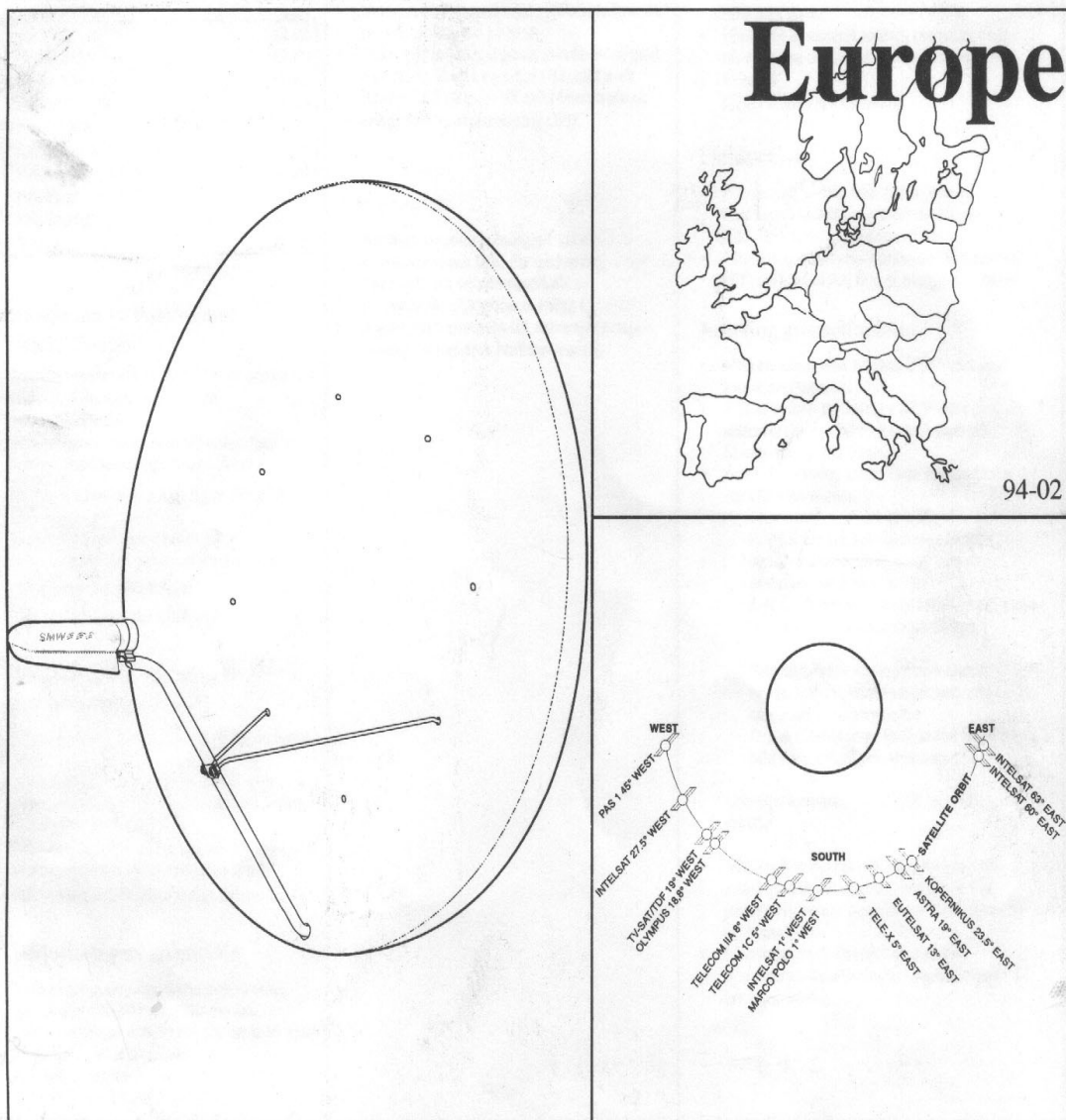

94-02

SMW
SWEDISH MICROWAVE AB

Monteringsanvisning
Installation instructions

MONTERING

(Figurer A–D)

Paketet innehåller:

	Art.nr	antal
1 Antennskål Ø 140 cm med fäste		(1 st)
2 Polarmount		(1 st)
3 LNB med ferotor		(1 st)
4 LNB-arm		(1 st)
5 Twinstag		(2 st)
6 Skruv M8 x 75		(2 st)
7 Skruv M8 x 50		(2 st)
8 Skruv M8 x 25		(1 st)
9 Låsmutter M8		(5 st)
10 Mutter M8	I PÅSE	(4 st)
11 Låsmutter M6		(4 st)
12 Bricka stor 25/8,5		(3 st)
13 Bricka stor 16/8,5		(2 st)
14 Plåtöverfall		(2 st)
15 V-byglar		(2 st)

A Montering av Polarmount och LNB-arm

- Montera maeströret lodrätt som antennen ska sitta på. Rördiametern 76 mm rekommenderas.
- Montera ihop polarmountet enligt figurena. Låt antennskålen ligga kvar i lådan.
- Montera LNB-arm enligt figur, dra ej åt skruvarna.
- Montera twinstagen i hålen på antennskålen och plåtöverfallen mellan markeringarna enligt figur.
- Dra åt skruvarna för LNB-armen.

B Montering och justering av antennmotor (400 mm)

- Titta i kartan och uppskatta sidvinkeln för din ort.
- Med hjälp av vinkelvärdet, läs av motsvarande motorarmslängd i tabellen under (i kolumn för ditt område).
- Montera fast motorn på fästena och skruva ut motorarmen till avläst längd (se figur).
OBS! Montera brickan enligt figur.

C Förjustering av polaraxeln

- Titta i kartan och uppskatta polaraxelns inställning (längd i mm) för din ort.
- Justera in längden (C1) för din ort med hjälp av en linjal eller liknande.
- Dra åt muttrarna.

D Inställning av Tiltvinkel

- Titta i kartan och uppskatta tiltvinkeln för din ort.
- Justera in ävståndet D1 enligt figur.
- Lås fast.

INKOPPLING

(Figur E)

LNB / Ferotor

- Sätt ihop LNB, Ferotor och Matarhorn enligt dess bruksanvisning och montera på LNB-arm.
OBS! Ferotorkablar rakt ned.
- Använd koaxialkabeln för anslutning mellan LNB och satellitmottagaren.
- Montera en F-kontakt (E1) på koaxialkabeln för inkoppling till LNB:n.
- Skarva de två ledningarna från ferotorn med bipackade skarvkontakter (E2, bild a–d).
- Anslut LNB/ferotor till satellitmottagaren enligt dess bruksanvisning (E3).

Antennmotor

- Använd avsedda ledningar i kabeln och kopplingsboxen (E4) för anslutning enligt figur (E5) till antennmotorkabeln.
- Montera kopplingsboxen enligt figur E4.
- Anslut antennmotorn till antenntstyringsenheten enligt dess bruksanvisning.

INSTÄLLNING

(Figur F)

Sidvinkel (kompassriktning)

- Välj en Astrakanal med satellitmottagaren.
- Lossa muttrarna (F1) till rörklammorna tills antennen med ett visst motstånd kan vridas.
- Vrid sedan antennen försiktigt åt öster eller väster till Astra medan du samtidigt har uppsikt på TV-skärmen. Stanna när du får bild från Astra.
- Hittar du ej satellitkanalen, prova att ändra elevationen och vrida antennen fram- och tillbaka.
OBS! Ändra ej tiltvinkeln.

Finjustering

- När du fått in bild från Astra justera antennen i sidled (azimuth) till bästa bild. Dra åt rörklammorna (F1).
- Finjustera antennens höjdvinkel (elevation) (F2) till bästa bild. Dra åt muttrarna efteråt.

Justering av satellitbanan

- Välj en kanal från Intelsat 27.5° väst med satellitmottagaren.
- Kör antennen till Intelsat 27.5° väst med antenntstyringsenheten (västknappen). Stanna när du har bästa.
- Är bilden brusig, kontrollera om antennen har rätt elevationen.

Blir bilden bra när antennen ändras uppåt, lossa rörklammorna och vrid antennen ca: 2 mm åt väst.
Dra åt klammorna. Ställ sedan in till bästa bild med antenntstyringsenheten.

Blir bilden bra när antennen ändras nedåt, lossa rörklammorna och vrid antennen ca: 2 mm åt öst.
Dra åt klammorna. Ställ sedan in till bästa bild med antenntstyringsenheten.

Upprepa ovanstående tills bästa bild erhålls.

- Välj en Astrakanal och kör antennen till Astra med antenntstyringsenheten. Finjustera vid behov höjdvinkeln (elevationen) till bästa bild.
- Utrustningen är därmed klar att programmeras. Se antenntstyringsenhetens bruksanvisning.

MOUNTING (Figures A-D)

The pack contains:

	Part no.	Qty
1 Antenna dish Ø 140 cm with bracket		(1)
2 Polar mount		(1)
3 LNB with Ferotor		(1)
4 LNB-arm		(1)
5 Twin-stay		(2)
6 Screw M8 x 75		(2)
7 Screw M8 x 50		(2)
8 Screw M8 x 25		(1)
9 Locking nut M8	BAG	(5)
10 Nut M8		(4)
11 Locking nut M6		(4)
12 Washer 25/8,5		(3)
13 Washer 16/8,5		(2)
14 Clamps for Twin-stay		(2)
15 U-bolt		(2)

A Polar mount and LNB-arm mounting

- First you need a vertical tube to put the antenna on. We recommend a diameter of 76 mm.
- Mount the polar mount according to the figures. Let the antenna be in the box.
- Mount the LNB-arm according to the figures, don't tighten the nuts.
- Mount the Twin-stay s in the holes of the antenna and the clamps between the lines.
- Tighten the nuts for the LNB-arm.

B Antenna actuator (400 mm) mounting and presetting

- Refer to the map for your country and estimate the azimuth angle for your location.
- By means of the angle value used in the table for your area unscrew the actuator arm to the corresponding length (B1) (mm).
- Mount the actuator according to the figure. (note the washer).

C Polaraxis presetting

- Refer to the map and estimate polar axis setting (length in mm) for your location.
- Adjust to the length (C1) for your location by means of a graduated rule and the adjusting nuts (C2). Tighten the nuts (C2).

D Tilt declination adjusting

- Refer to the map and estimate the tilt declination for your location.
- Adjust the the distance D1 according to the figure.
- Tighten.

CONNECTIONS (Figure E)

LNB/Ferotor

- Fit together LNB, Polarizer and feed horn as described in its instruction manual and mount on the LNB-arm.
- Use the coaxial cable for connection between the LNB and the satellite receiver.
- Fit an F-connector (E1) to the coaxial cable to connect it to the LNB.
- Join the two cables from the ferotor with the splicing connectors supplied (E2, figures a-d).
- Connect the satellite receiver as described in its instruction manual (E3).

Antenna actuator

- Use the actuator cable and junction box (E4) to connect the antenna actuator to the antenna control unit (E5).
- Mount the junction box according to the figure E4.
- Connect the antenna control unit as described in its instruction manual.

SETTING UP (Figure F)

Azimuth (compass bearing)

- Select an Astra channel with the satellite receiver.
- Slacken the tube clamp nuts (F1) until the antenna can just be moved against the friction around the U-tube, and point the antenna towards south.
- Carefully swing the antenna towards the east, while observing the TV screen. Stop when an Astra picture appears. If you fail to locate the signal, try to adjust the elevation and swing the antenna back and forth.
- Don't change the tilt declination.

Fine adjustment

- When you have an Astra picture, adjust the antenna in azimuth for the best picture, then secure the antenna by tightening the nuts (F1).
- Adjust the elevation using the adjustment nuts (F2) for the best picture. Tighten the nuts.

Satellite orbit adjustment

- Select a channel from Intelsat 27.5° west with the satellite receiver.
- Move the antenna to Intelsat 27.5° west with the antenna control unit (west button). Stop when you have the best picture.
- If the picture is "snowy" try to change the elevation:

If the picture is good when the antenna changing upwards, slacken the tube clamps and turn the antenna about 2 mm towards west.

Tighten the clamps and fine adjust with the antenna control unit until the best picture is obtained.

If the picture is good when antenna changing downwards, slacken the tube clamps and turn the antenna about 2 mm towards east.

Tighten the clamps and fine adjust for with the antenna control unit until the best picture is obtained.

Repeat the procedure for best picture.

- Select an Astra channel and move the antenna to Astra. If necessary, fine adjust the elevation for best picture.
- The equipment is therewith ready for programming. See manual for antenna control unit.

MONTERING - MOUNTING

A

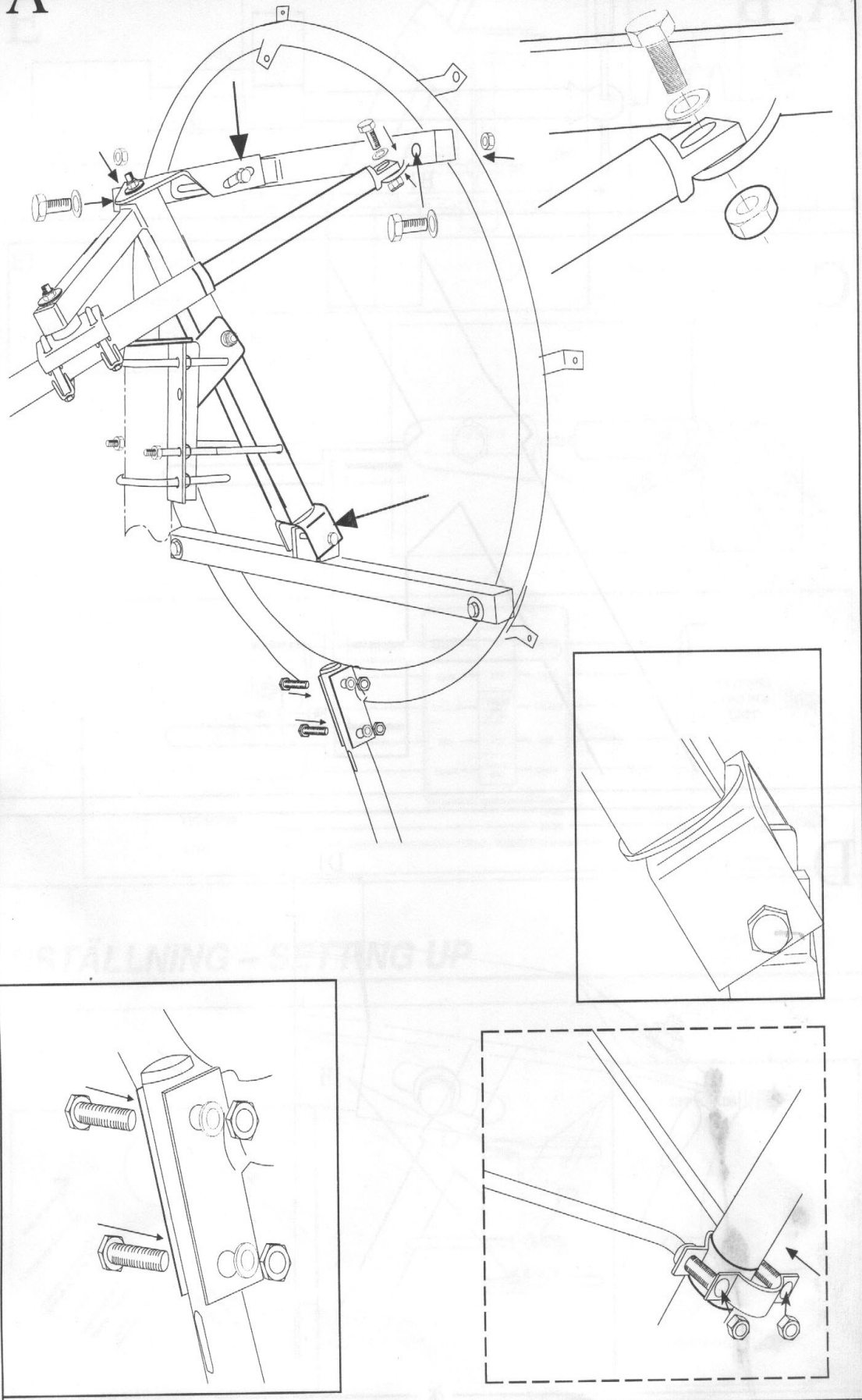

STALLING - SITTING UP

MONTERING - MOUNTING

A, B

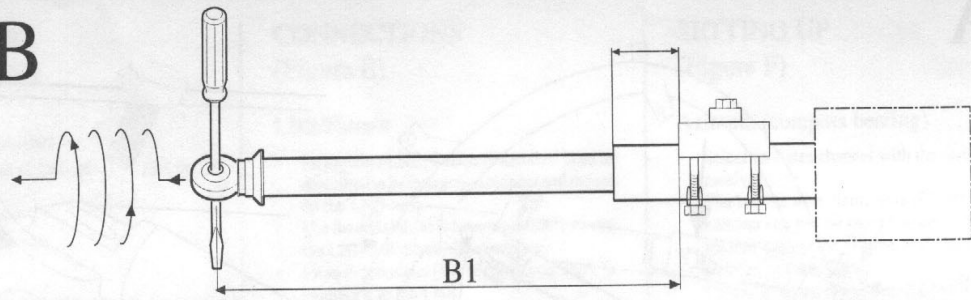

C

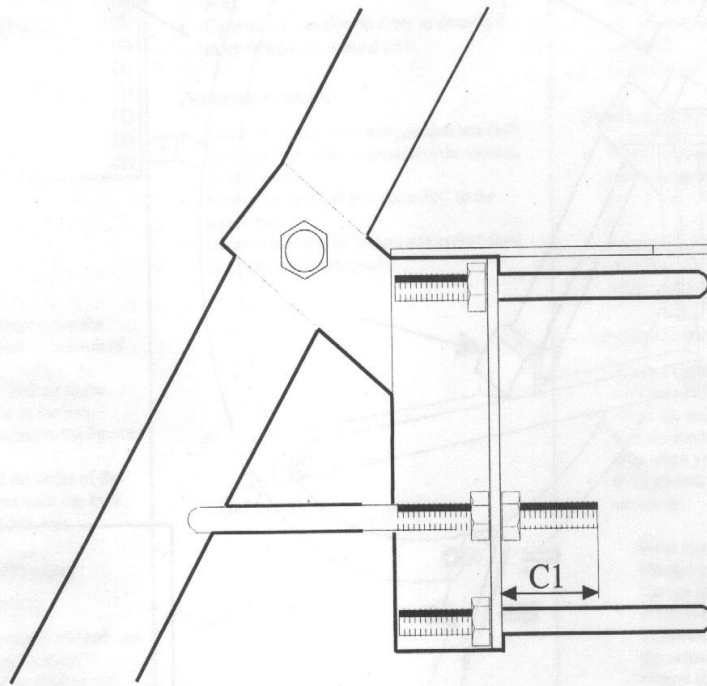

D

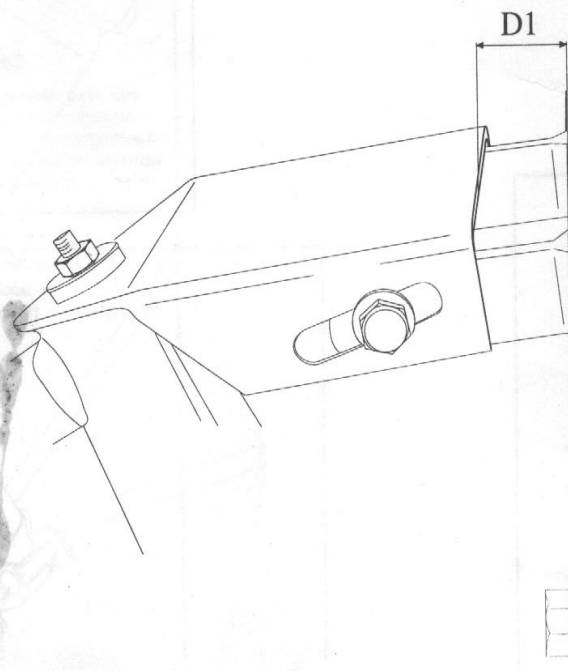

INSTALLING - CONNECTIONS

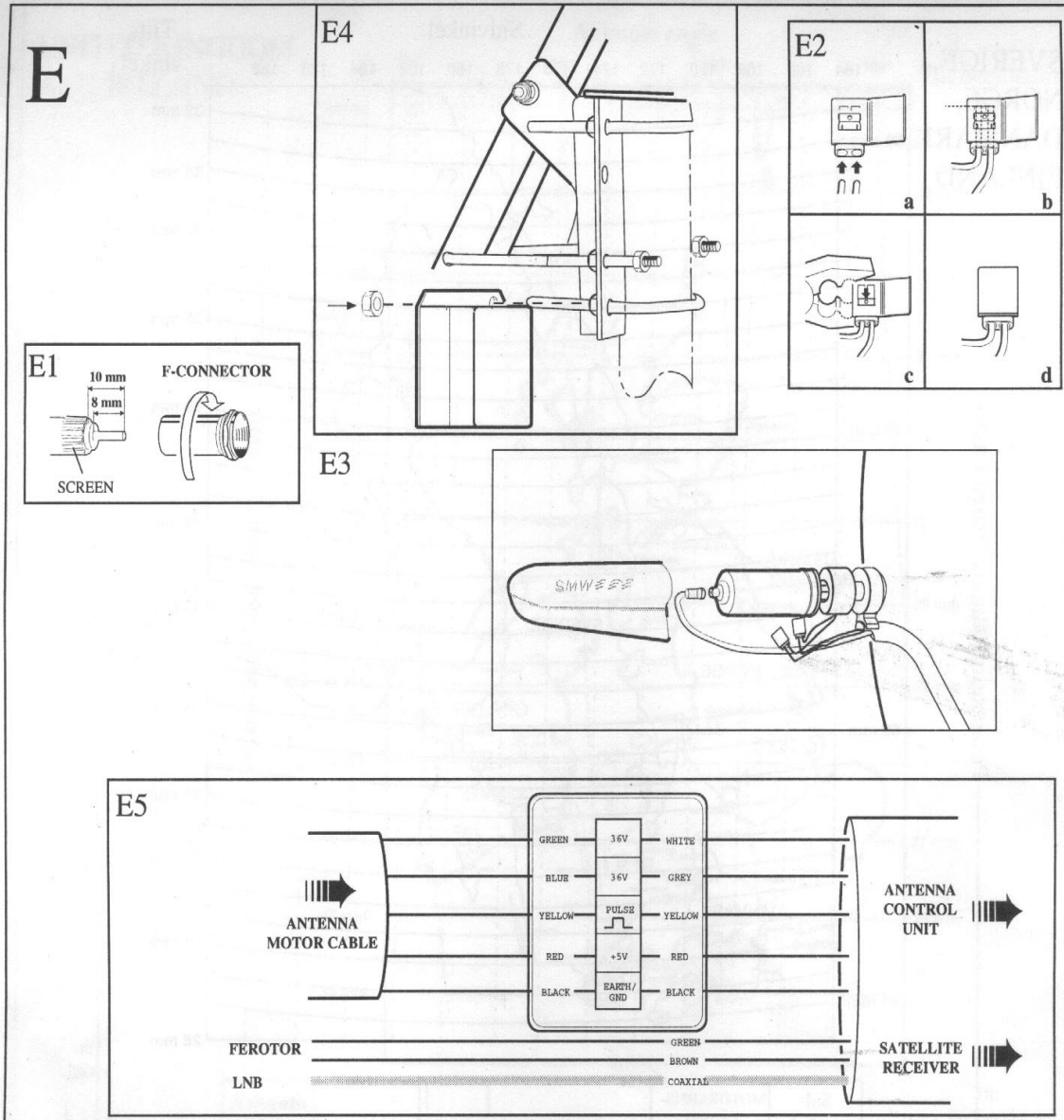

INSTÄLLNING - SETTING UP

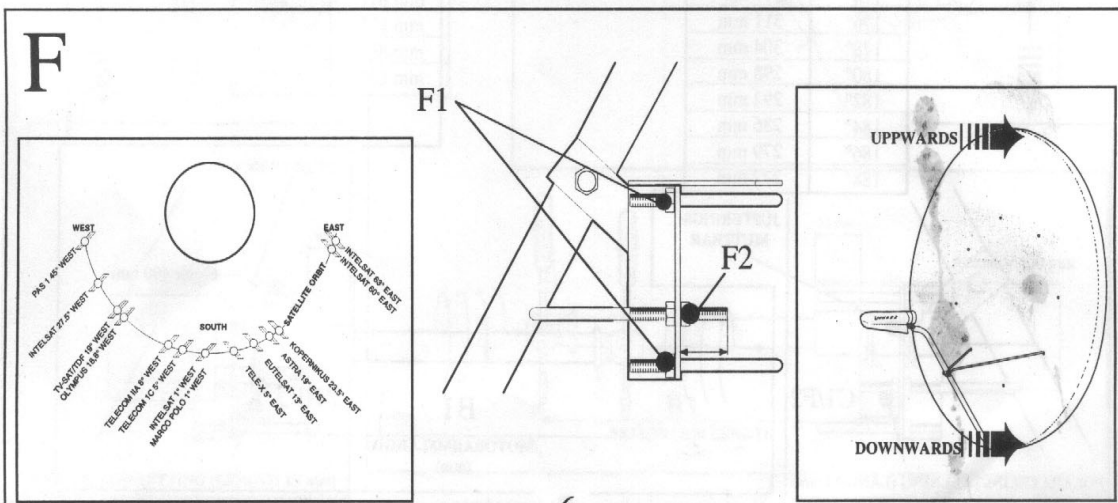

ANTENNINSTALLNINGSKARTA

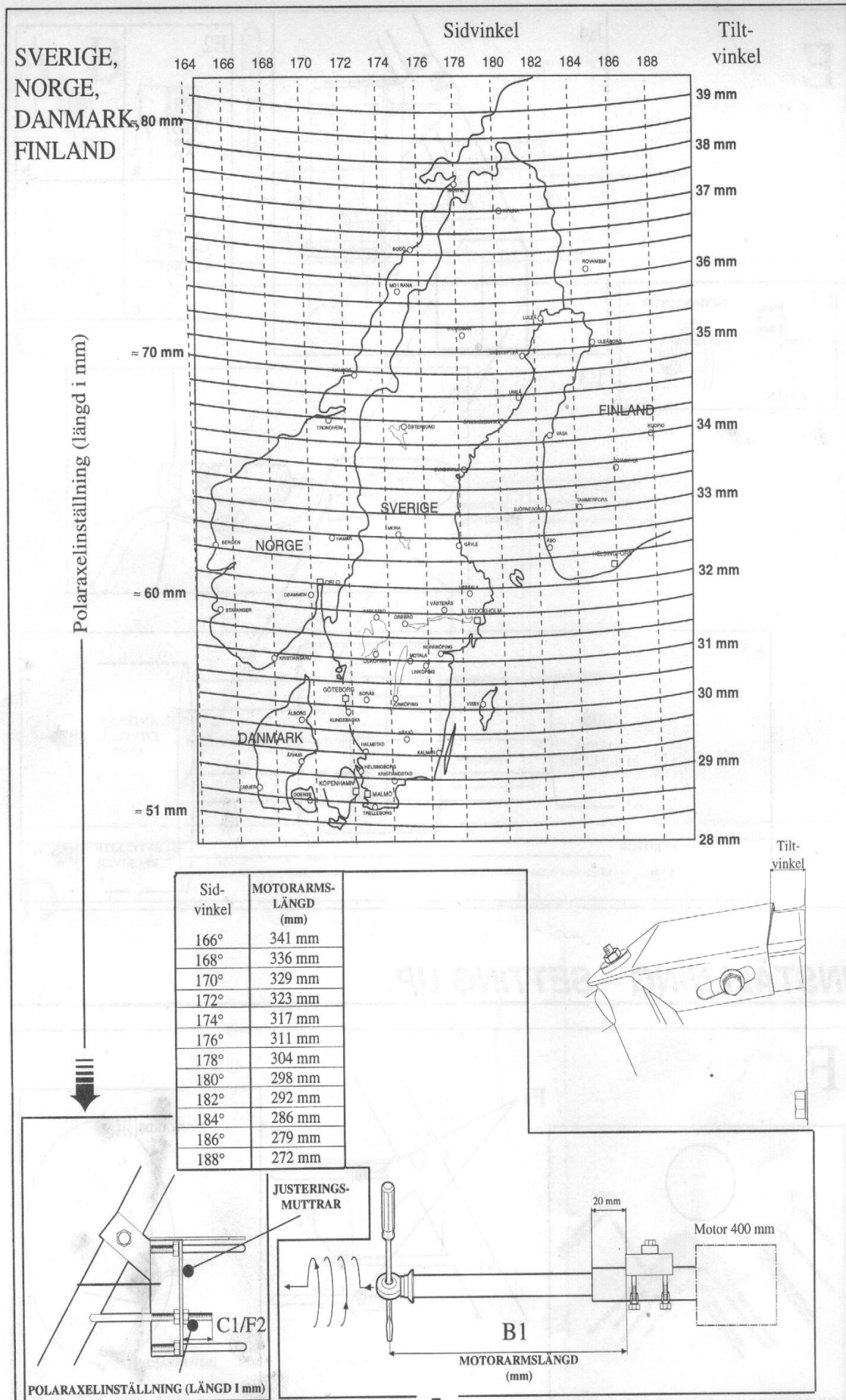

UNITED KINGDOM AND IRELAND

Polar axis setting (length in mm)

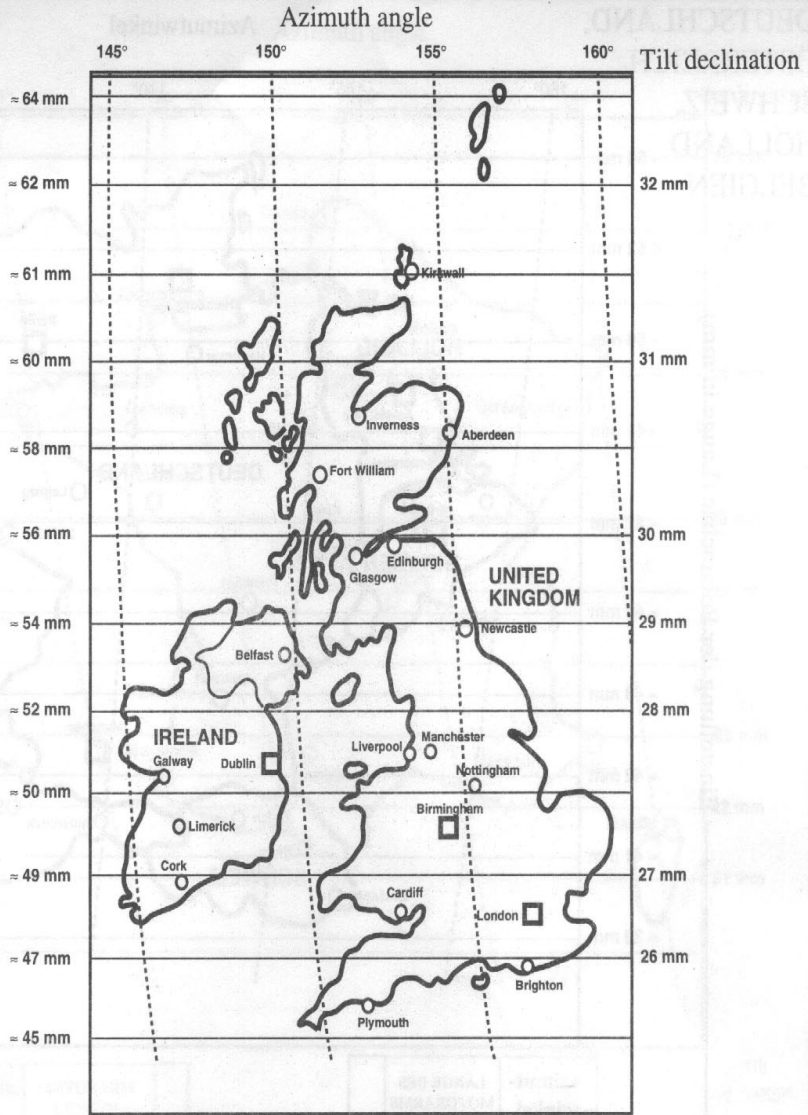

Azimuth angle	
144°	397 mm
146°	392 mm
148°	388 mm
150°	383 mm
152°	378 mm
154°	374 mm
156°	368 mm
158°	363 mm

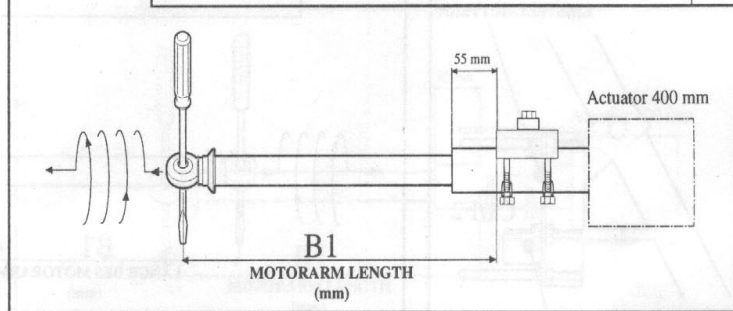
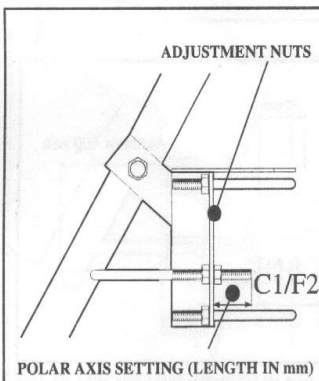
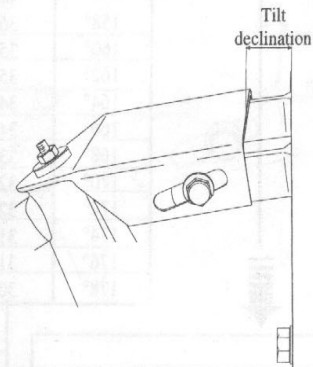

KARTE FÜR EINSTELLUNG DER ANTENNE

DEUTSCHLAND,
ÖSTERREICH,
SCHWEIZ,
HOLLAND
BELGIEN

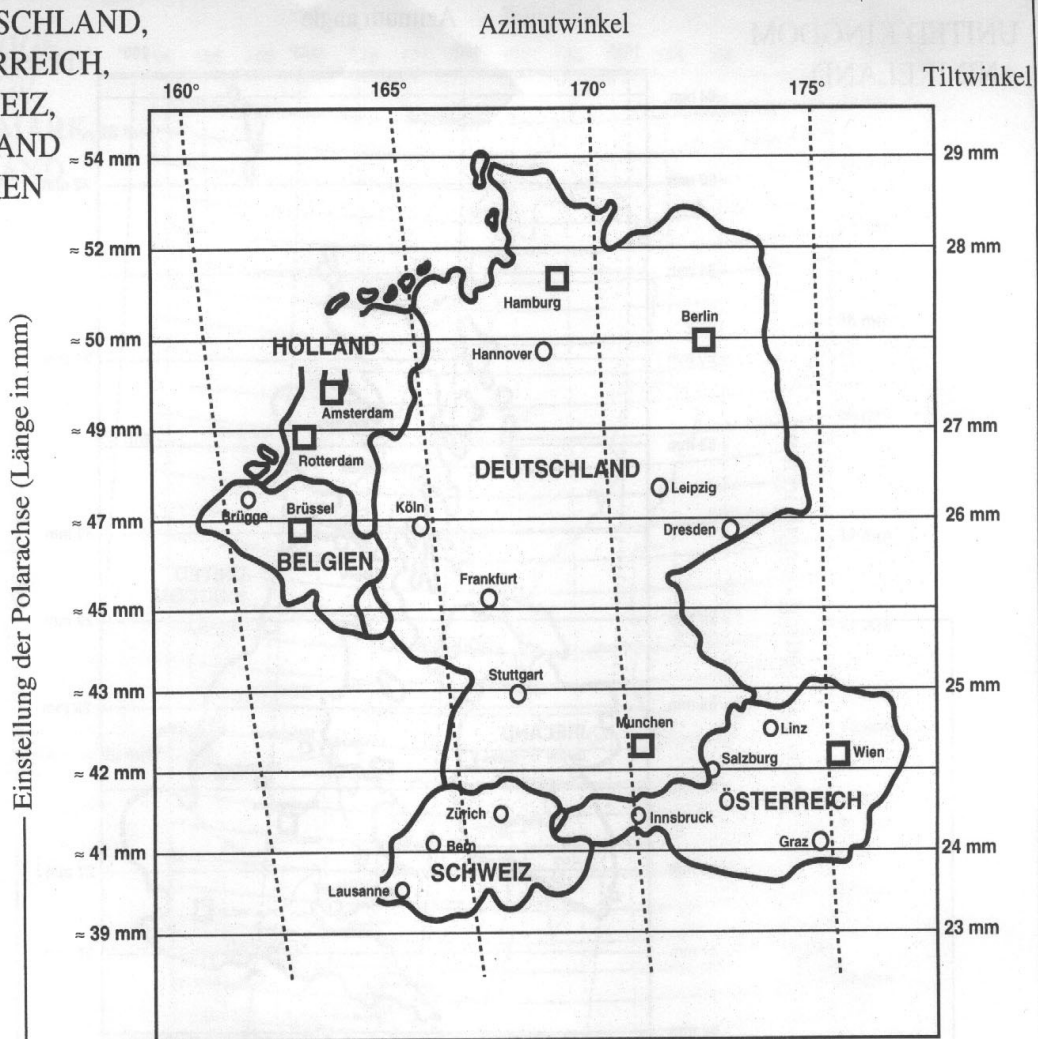

Azimutwinkel	LÄNGE DES MOTORARMS (mm)
158°	363 mm
160°	358 mm
162°	353 mm
164°	347 mm
166°	341 mm
168°	336 mm
170°	329 mm
172°	323 mm
174°	317 mm
176°	311 mm
178°	304 mm

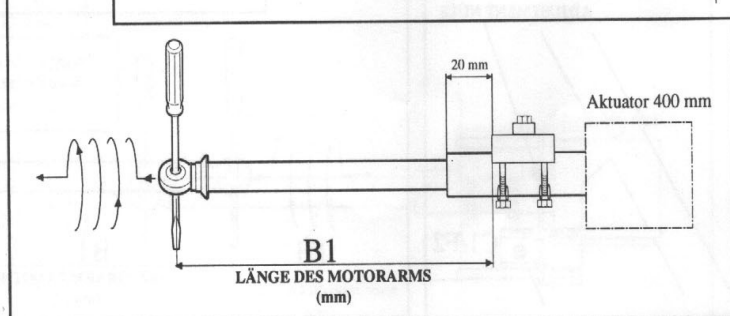
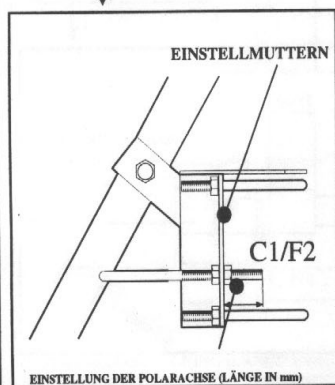
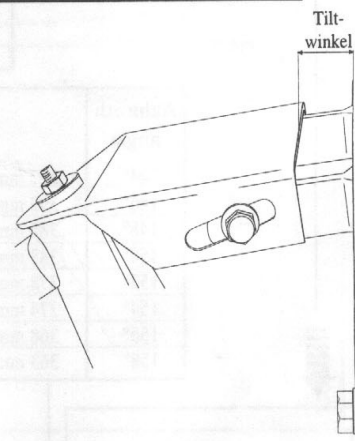

ANTENNA ADJUSTMENT MAP

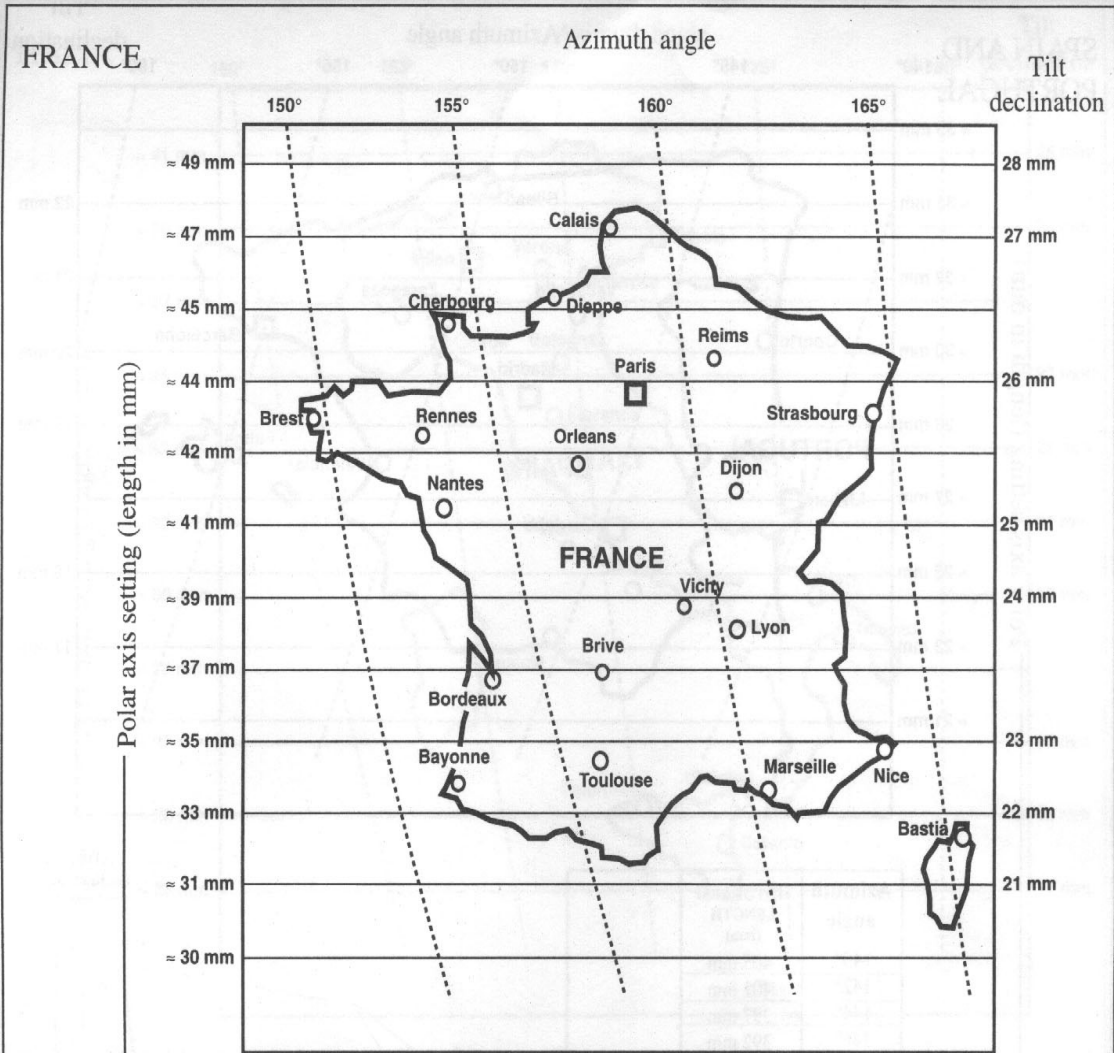

Azimuth angle	MOTORARM LENGTH (mm)
148°	388 mm
150°	383 mm
152°	378 mm
154°	374 mm
156°	368 mm
158°	363 mm
160°	358 mm
162°	353 mm
164°	347 mm
166°	341 mm
168°	336 mm

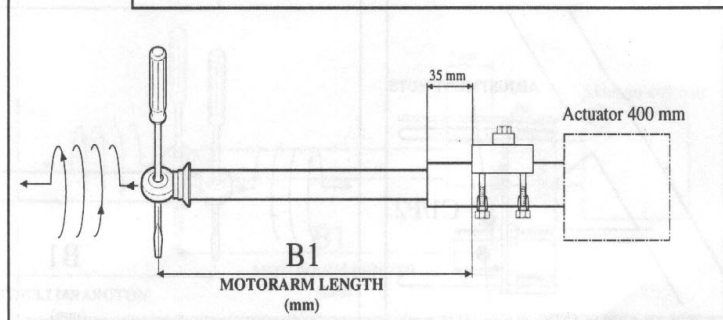
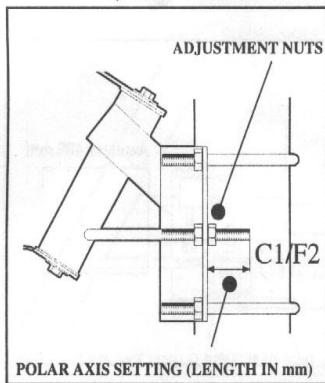
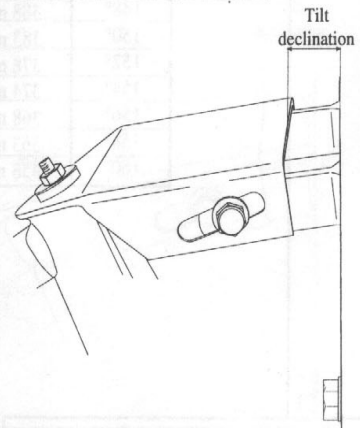

ANTENNA ADJUSTMENT MAP

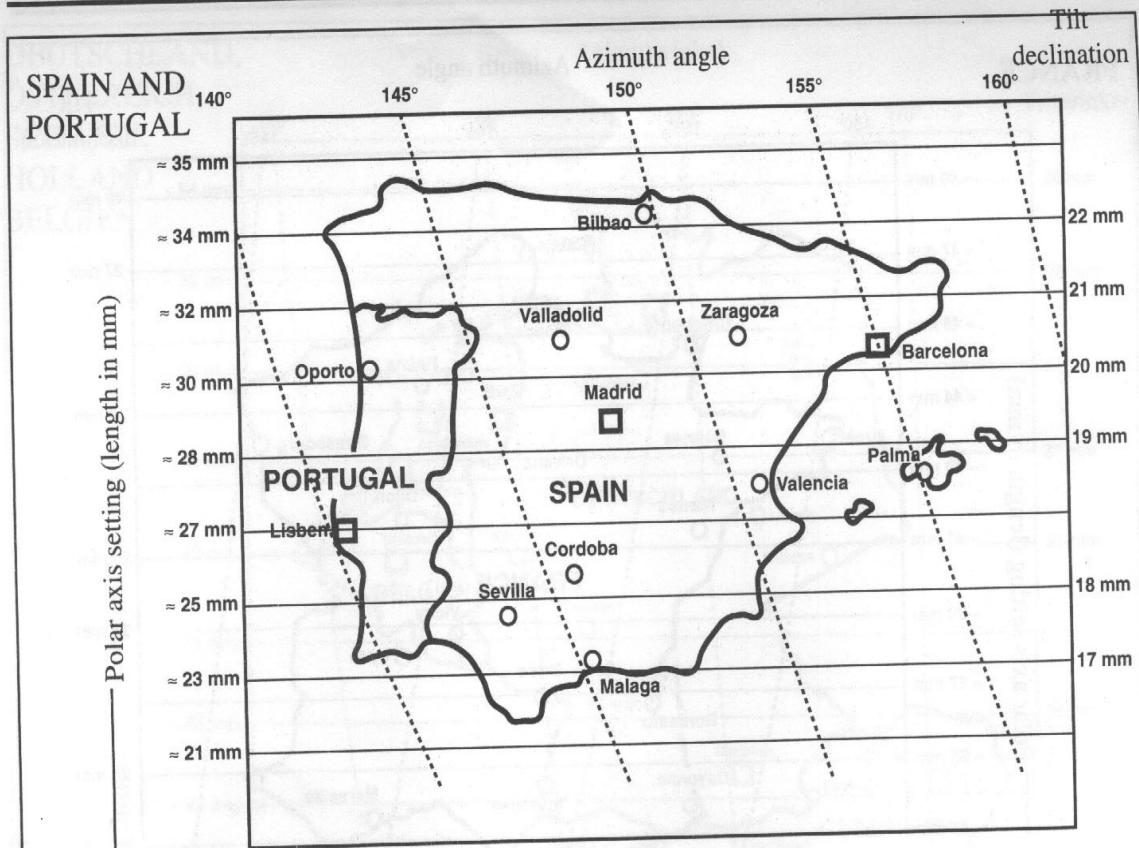

Azimuth angle	MOTORARM LENGTH (mm)
140°	405 mm
142°	401 mm
144°	397 mm
146°	392 mm
148°	388 mm
150°	383 mm
152°	378 mm
154°	374 mm
156°	368 mm
158°	363 mm
160°	358 mm

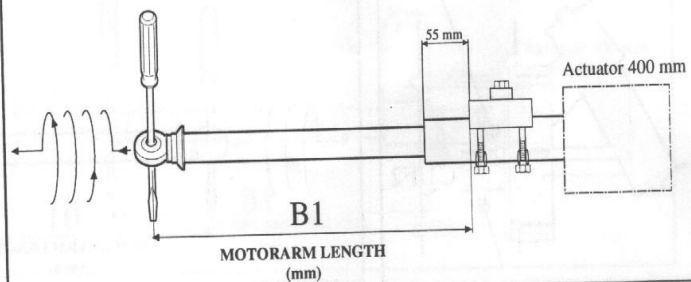
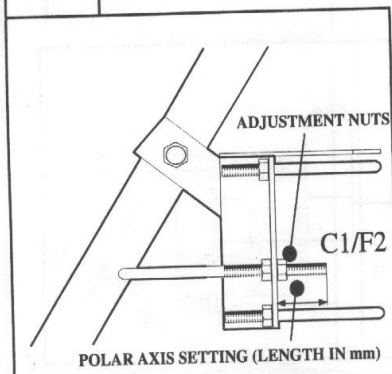
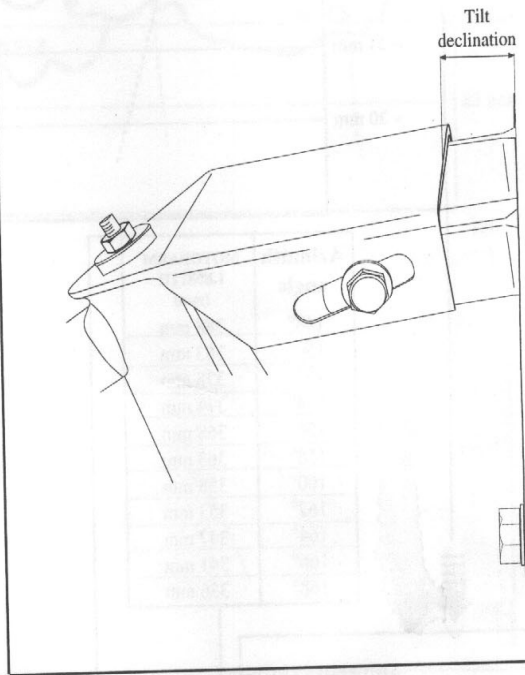

ANTENNA ADJUSTMENT MAP

ITALIA

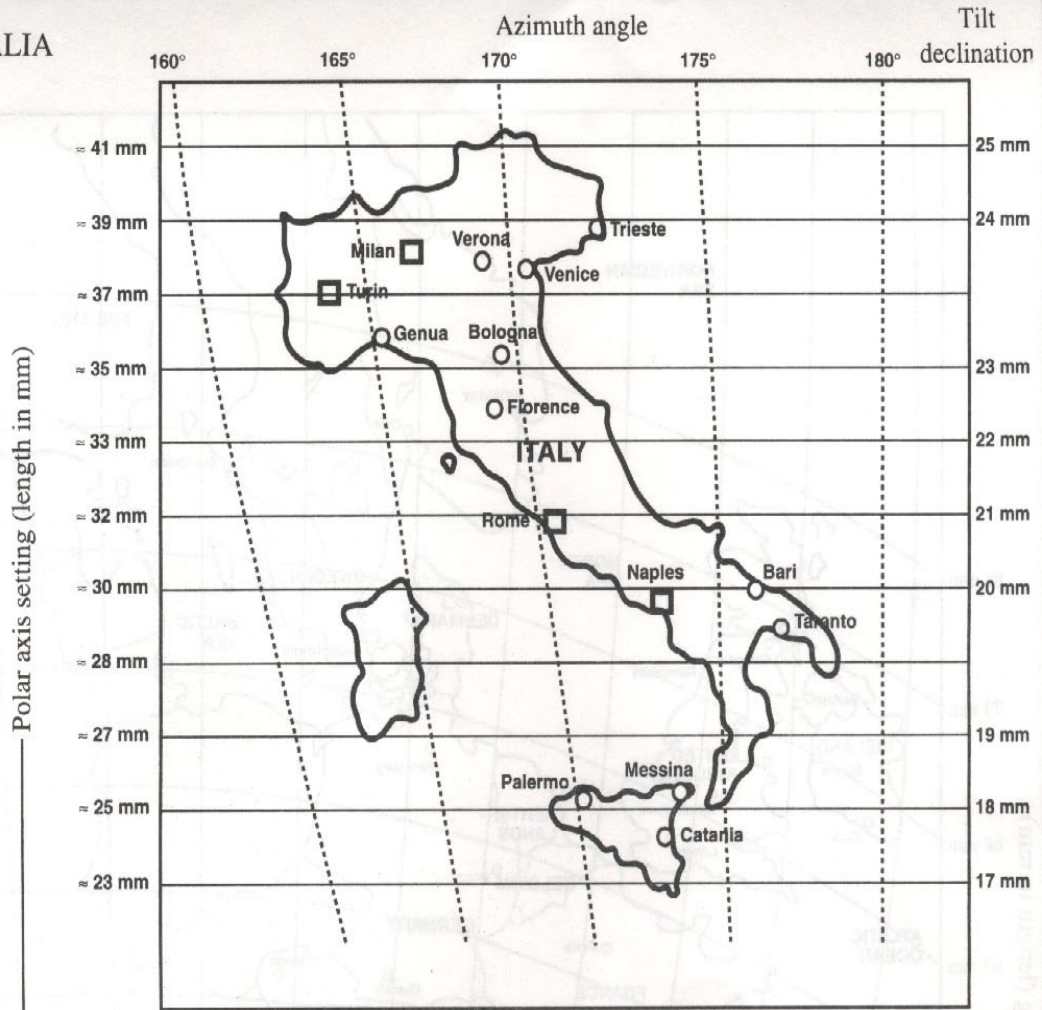

Azimuth angle	MOTORARM LENGTH (mm)
160°	358 mm
162°	353 mm
164°	347 mm
166°	341 mm
168°	336 mm
170°	329 mm
172°	323 mm
174°	317 mm
176°	311 mm
178°	304 mm
180°	298 mm

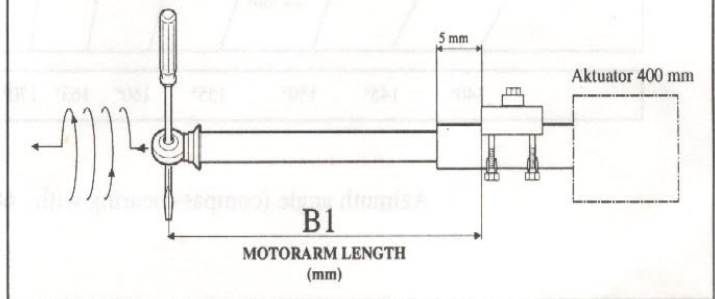
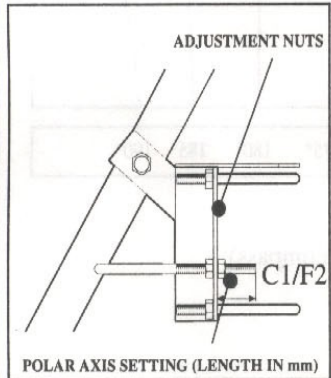
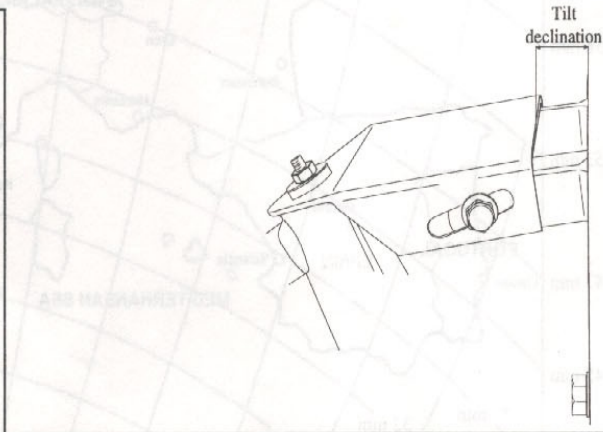

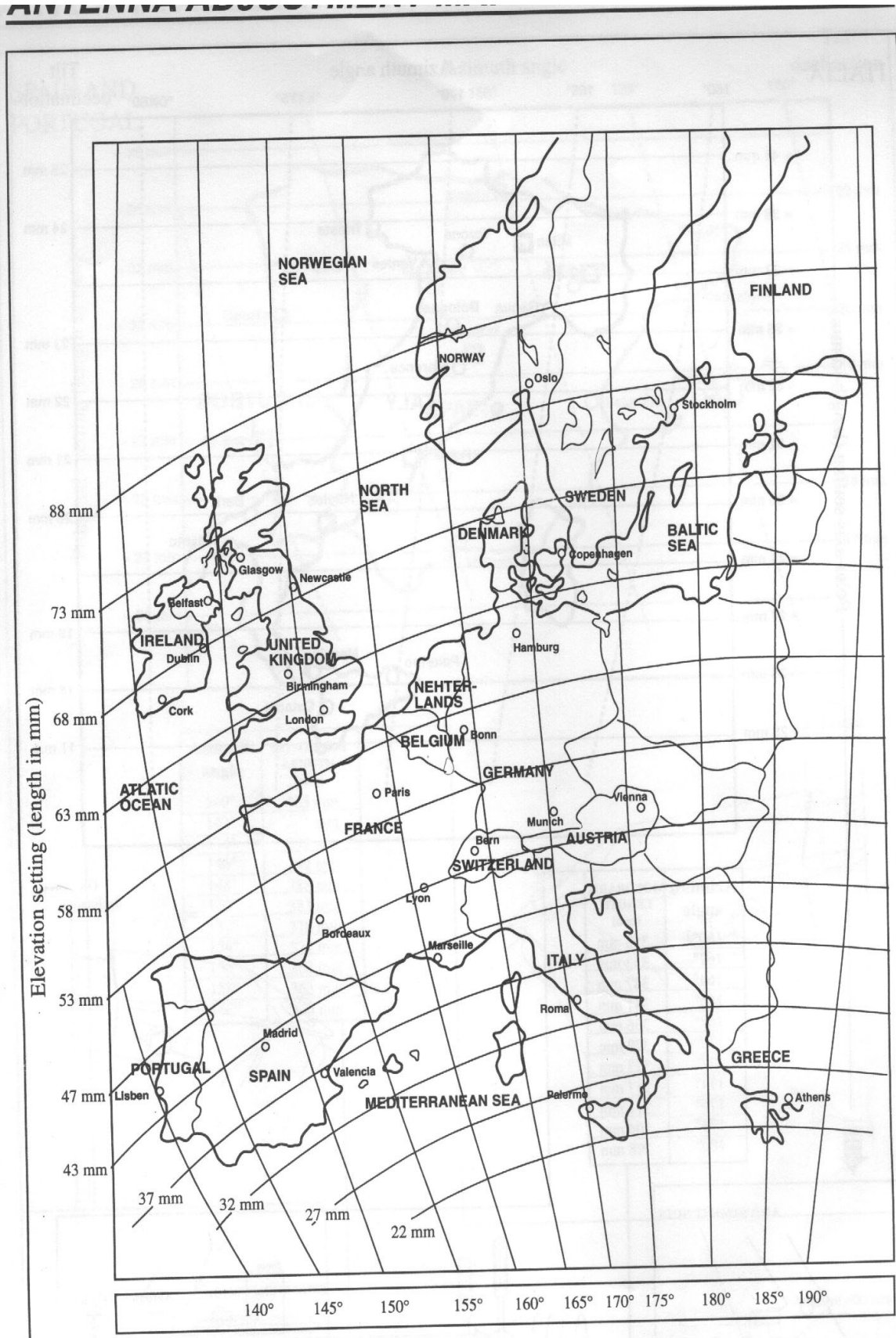

Azimuth angle (compass bearing with 360° compass)